

---

# Installation guide

19" Rack Mount, 1U,  
Multi-channel Loudspeaker  
Protection Unit

## APU-RS8iC APU-RS16iC





---

# Index

Caution: Read before installing these products.....	4
Introduction .....	4
Compatibility .....	4
Speaker settings.....	5
Check model numbers.....	5
Cautions when changing speaker settings.....	5
Speaker settings.....	6
Changing settings.....	6
Recording settings .....	6
Connection.....	7
Connection cautions.....	7
Wiring diagram.....	7
Wiring the speaker connectors.....	8
Fitting the connectors.....	8
Positioning.....	9
Front panel mounting .....	9
Operation.....	9
Cautions in use.....	9
Using the APU-RS16iC/RS8iC.....	9
Troubleshooting.....	10
Specifications.....	10
Warranty .....	10

---

## Caution: Read before installing these products

- To ensure optimal performance, please read this guide carefully. Keep it in a safe place for future reference.
- Install this product in a cool, dry and clean place - away from direct sunlight, heat sources, vibration, dust and moisture.
- Do not expose this unit to sudden temperature changes or locate it in an environment with high humidity. This is to prevent condensation forming inside which may cause damage to this unit and possibly to devices connected to it.
- Do not clean this unit with chemical solvents as this might damage the finish. Use a clean, dry or damp cloth.
- Do not attempt to modify or repair this unit.
- Be sure that all connections are made in accordance with this guide
- Contact your distributor or the manufacturer if a fault should occur.
- This unit features internal jumpers that may be adjusted by the installer. Take care when removing and re-fitting the lid not to damage the four machine screws. Ensure the screws are tight when re-fitting them.
- This product does not require any power connection. Never attempt to connect mains or any other power source to it.

## Introduction

### Compatibility

The APU-RS8iC and APU-RS16iC have been designed specifically to enhance the sound and reliability of Amina Edge Series and Mobius Series loudspeakers.

Compatible models are listed in the table below.

Model	Compatible Speakers
APU-RSiC 8/16	Edge3i/5i/7i; Mobius3i/5i/7i; Mobius5i-S200; MobiusDual i,

The APU-RSiC features a separate high-pass filter and a current sensing re-settable fuse to protect each loudspeaker from being over-driven and potentially damaged.

If the APU-RSiC senses excessive drive current from the system's amplifier it will automatically reduce the sound level from the speaker until the amplifier's volume is reduced.

**NOTE: APU-RSiC is not suitable for 100v/70v line systems (high impedance/fixed voltage), subwoofers or other manufacturers' loudspeakers.**

# Speaker settings

## Check model numbers

The protection provided by the APU-RSiC is divided into four protection groups as shown in the table below.

Group	Compatible models
APU-RSiC 8/16	
1	Factory default
3	Edge3i, Mobius3i, MobiusDual i
5	Edge5i, Mobius5i, Mobius5i/S200
7	Edge7i, Mobius7i

NOTE: The factory setting for all jumpers is Group 1. If not changed from this default setting, higher performing loudspeakers will have their performance characteristics limited.

## Cautions when changing speaker settings



Ensure that each channel is correctly set to match the connected speaker before use. Failure to do so could result in speaker damage.

- The APU-RS8iC and APU-RS16iC are low voltage, passive devices, however ALWAYS disconnect them from all speakers and amplifiers before changing speaker settings.
- Ensure that jumpers are fully pushed down onto their pins when changing settings.
- Only fit one jumper for each channel.
- Ensure the lid is securely fitted to the product after changing settings.
- Only remove and replace the lid fixing screws by hand. Always use the correct tool and do not over tighten.
- Before changing any settings, make a note of which speaker model will be connected to each channel of the APU-RS.

# Speaker settings

## Changing settings

- Unscrew the four screws on the sides of the chassis.
- Remove the lid.
- Identify the 8 or 16 configuration jumpers located on the PCB (two are shown in the enlarged diagram on the right).

*Each jumper has four settings marked on the PCB - 1, 3, 5 and 7. In the diagram, the arrowed jumpers are set to the factory setting - group 1.*

- Referring to the table at the start of this section, set each jumper to the correct setting for the connected speaker.
- Check that all settings have been correctly made.
- Re-fit the lid.

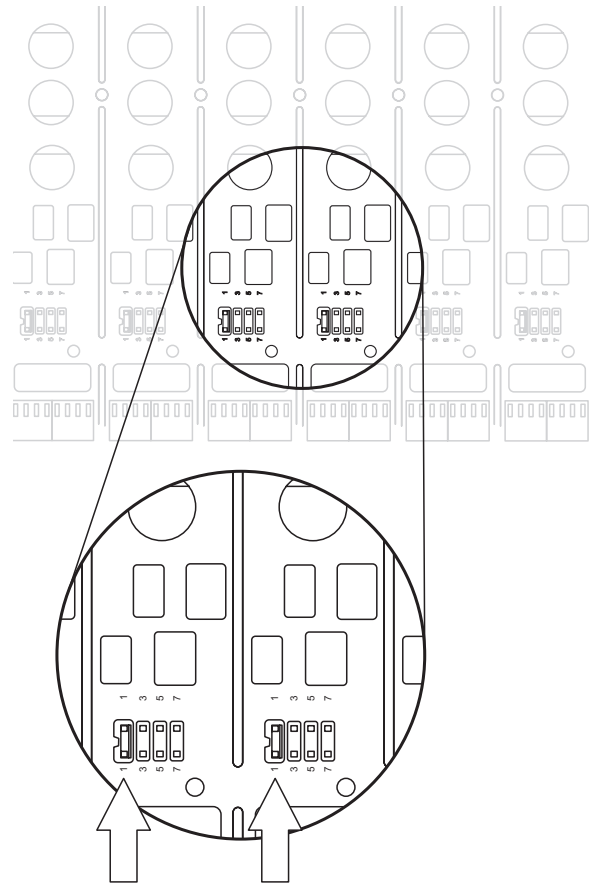

## Recording settings

There is an area on the product serial number label where the fuse settings can be marked for each channel once the jumpers have been set.

The label drawing below shows an example of a system that has 10 speakers connected of differing types.



**IMPORTANT:**  
ENSURE CORRECT SPEAKER MODEL  
IS USED ON EACH CHANNEL.



CHANNEL FUSE SETTINGS:

	CH1	CH2	CH3	CH4	CH5	CH6	CH7	CH8	CH9	CH10	CH11	CH12	CH13	CH14	CH15	CH16
Group 1	<input type="checkbox"/>	<input type="checkbox"/>	<input type="checkbox"/>	<input type="checkbox"/>	<input type="checkbox"/>	<input type="checkbox"/>	<input type="checkbox"/>	<input type="checkbox"/>	<input checked="" type="checkbox"/>	<input checked="" type="checkbox"/>	<input type="checkbox"/>	<input type="checkbox"/>	<input type="checkbox"/>	<input type="checkbox"/>	<input type="checkbox"/>	<input type="checkbox"/>
Group 3	<input type="checkbox"/>	<input type="checkbox"/>	<input type="checkbox"/>	<input type="checkbox"/>	<input type="checkbox"/>	<input type="checkbox"/>	<input type="checkbox"/>	<input type="checkbox"/>	<input type="checkbox"/>	<input type="checkbox"/>	<input type="checkbox"/>	<input type="checkbox"/>	<input type="checkbox"/>	<input type="checkbox"/>	<input type="checkbox"/>	<input type="checkbox"/>
Group 5	<input type="checkbox"/>	<input type="checkbox"/>	<input checked="" type="checkbox"/>	<input checked="" type="checkbox"/>	<input checked="" type="checkbox"/>	<input checked="" type="checkbox"/>	<input type="checkbox"/>	<input type="checkbox"/>	<input type="checkbox"/>	<input type="checkbox"/>	<input type="checkbox"/>	<input type="checkbox"/>	<input type="checkbox"/>	<input type="checkbox"/>	<input type="checkbox"/>	<input type="checkbox"/>
Group 7	<input checked="" type="checkbox"/>	<input checked="" type="checkbox"/>	<input type="checkbox"/>	<input type="checkbox"/>	<input type="checkbox"/>	<input type="checkbox"/>	<input checked="" type="checkbox"/>	<input checked="" type="checkbox"/>	<input type="checkbox"/>	<input type="checkbox"/>	<input type="checkbox"/>	<input type="checkbox"/>	<input type="checkbox"/>	<input type="checkbox"/>	<input type="checkbox"/>	<input type="checkbox"/>

Serial No.

16 Channel  
Protection  
Unit

## APU-RS16iC

Amina Technologies Ltd  
Huntingdon, Cambridgeshire, PE29 7DL  
Made in the U.K.

# Connection

## Connection cautions

- NEVER connect more than one loudspeaker to an output channel.
- It is not recommended to connect amplifiers with power outputs that are far greater than the loudspeaker's peak power rating.

## Wiring diagram

The diagram below shows an example of the wiring for channels 1 and 2.

Each channel of the amplifier is wired to the 'AMP' terminals of one of the APU-RS channels.

The corresponding speaker is wired to the 'SPK' terminals of the same channel.

NOTE: The + terminals of the amplifiers and speakers must connect to the + terminals of the APU-RSiC to maintain correct polarity all the way from amplifier to speaker.

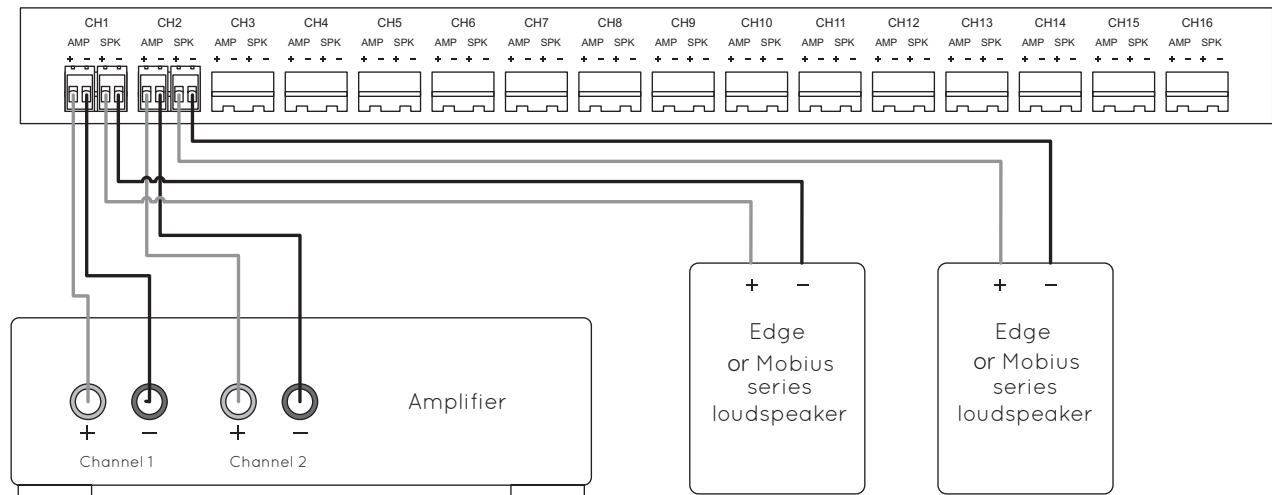

# Connection

## Wiring the speaker connectors

The speaker connectors are supplied packed separately with the APU-RSiC to simplify the fitting of cables from each amplifier and speaker channel.

- Strip each cable back by 6-8mm and twist the wire ends.
- Identify the polarity of the cable. The + cable is usually marked with a stripe or a rib.

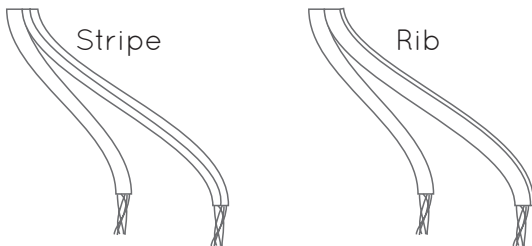

*The + cable must be connected only to + terminals throughout the system (at the APU-RSiC, the amplifier and the speaker).*

- Unscrew the cable fixing screws.
- Pass the speaker cable into the terminal openings.

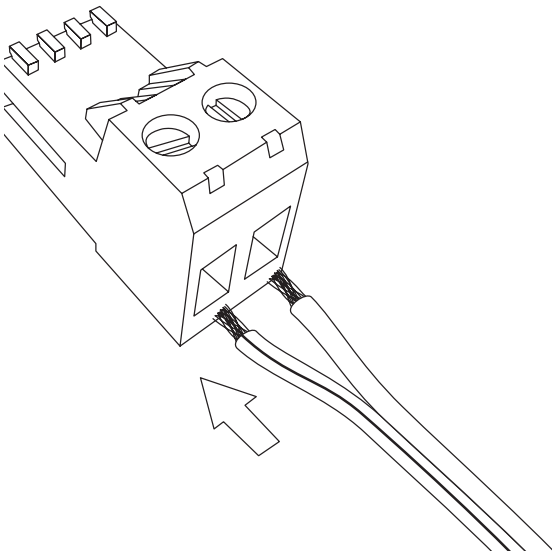

*To maintain polarity the + cable must always be connected to the LEFT terminal.*

- Tighten the fixing screws to secure the cable.

## Fitting the connectors

- Each connector can now be fitted by pressing it into the opening on the back of the APU-RSiC.  
*The slot in the connector should engage with the edge of the PCB inside the opening.*

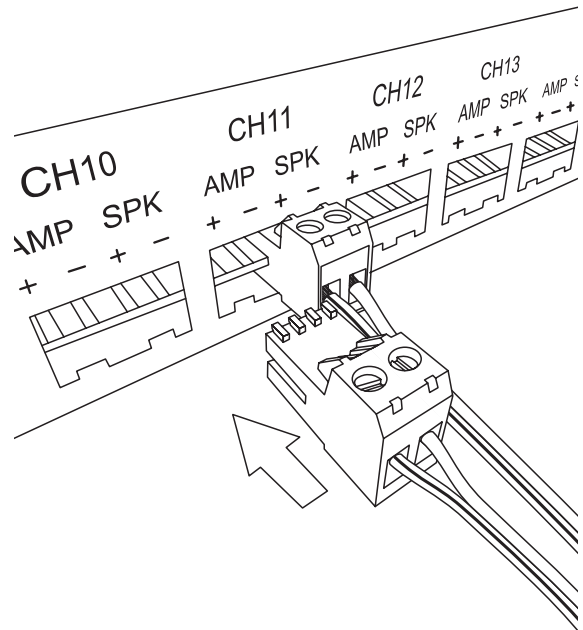



# Positioning

## Front panel mounting

The APU-RSiC is designed to fit into a standard 19 inch equipment rack via 4 mounting holes in the front panel and has a height of 1U (45mm/1 3/4 inches).

The fixing hole dimensions are shown in the diagram below.

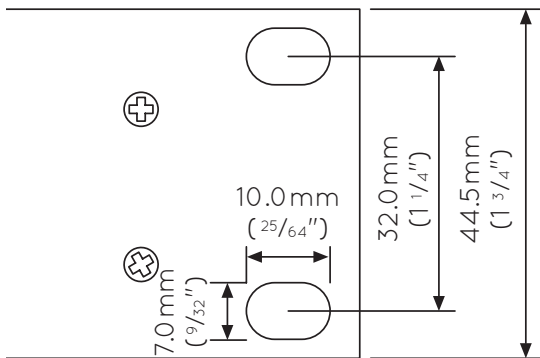

Alternatively, the APU-RSiC can be placed on a shelf. Other equipment (up to 10kg/22lbs) may be placed on top if necessary. Take care not to scratch the top of the case and that any weight is not directly over the center of the APU-RS.

**NOTE:** The APU-RSiC does NOT require ventilation and therefore its installation position is not critical.

The APU-RSiC should ALWAYS be installed in a dry environment that does not exceed 35 degree Centigrade (95 degree Fahrenheit).

The product's steel case provides all necessary shielding from magnetic fields generated by the APU-RSiC itself (these are very small) or from other equipment placed nearby.

# Operation

## Cautions in use

It is not recommended that you intentionally cause the APU-RSiC to automatically protect the loudspeakers by deliberately over-driving them. If you find that the APU-RSiC automatically reduces the audio volume from the loudspeakers frequently it may suggest that the amplifier being used is too powerful or that the layer of plaster over the speakers is too thick.

**WARNING: DO NOT** switch on the amplifier unless both APU-RSiC and loudspeakers are connected to it. Damage may occur to the amplifier if it is operated without a loudspeaker connected to the output of the APU-RSiC.

## Using the APU-RSiC

There are no controls on the APU-RSiC and no need to change any settings unless the model of connected speaker is changed.

# Troubleshooting

Symptom	Solution
No sound from one or more channels	Check that the sound source and all of the system amplifiers are switched on. If the problem persists, switch off the system and check that the connections to each channel have been correctly and securely made. Ensure that there are no whiskers of wire touching at the connectors and causing the signal to short-circuit.
Volume reduces periodically in one or more of the speakers	This may be due to over-driving. If so, reduce the volume. Never overdrive the system intentionally. There may be too much plaster over the speakers.

If you cannot resolve the problem, contact your supplier.

# Specifications

Dimensions:	1U height front panel, 482mm x 44.4mm (19" x 1 3/4"), case depth, 213mm (8 3/8")
Weight:	3.14kg (6lbs 14oz) Nett, 3.68kg (8lbs 2oz) Gross
Fuse protection:	Self-resetting, current sensing type. Fuse threshold set via internal jumpers
Compatibility APU-RS8iC/16iC	Suitable for use with Amina Edge3i/5i/7i; Mobius3i/5i/7i; MobiusDual i; Mobius5i-S200. Legacy speakers may not be supported, contact your supplier for information.
Number of channels:	8 or 16
Connection type:	Screw terminals
Maintenance requirements:	Protection fuses must be set by installer.

Repeated tripping of fuses may require fuse replacement to ensure optimal speaker performance.

# Warranty

The APU-RSiC is designed to operate reliably for many years. Correctly installed and operated in accordance with these instructions, Amina warrants the APU-RSiC against defective materials and workmanship for a period of two years.





---

*Amina*

T E C H N O L O G I E S L t d

Amina Technologies Ltd  
Cirrus House, Glebe Road  
Huntingdon, Cambs, PE29 7DL England  
T: +44 (0)1480 354390

W: [www.aminasound.com](http://www.aminasound.com) / E: [info@aminasound.com](mailto:info@aminasound.com)  
Copyright 2021

APU-RSi V1.3

---