

FEATURES

- Artistically crafted cabinet with shaped MicroPerf™ aluminum grilles look natural and realistic
- 6.5" dual voice coil injection-molded TCC (talc, carbon, and ceramic) filled polypropylene woofer with butyl rubber surround
- Dual 1" fluid-cooled tri-laminate Teteron tweeters mounted at a custom angle for optimum dispersion
- Separate left and right channel inputs provide stereo sound in a single loudspeaker projecting quality stereo sound over a larger area than conventional loudspeakers
- Weatherproof design ensures performance outdoors
- Designed to accommodate live plants
- Dual 3-foot burial-rated connection cables with waterproof wire-nuts to insure trouble free connection
- Can be wired in one-speaker stereo-input mode or two-speaker stereo mode

SPECIFICATIONS

Recommended Amplifier Power
10 to 100 Watts

Nominal Impedance
8 Ohm, in one-speaker stereo mode
4 Ohm, in two-speaker stereo mode

Wiring Requirements
2-conductor direct burial cable at the following sizes depending on longest length of cable required (2 per speaker in one-speaker stereo mode):

Wire Gauge	Maximum Distance
16	60 ft (18 m)
14	100 ft (30 m)
12	160 ft (50 m)

Temperature Extremes
-50° to 185° Fahrenheit
-45° to 85° Celsius

Shipping Dimensions
12 1/2" high x 28" wide x 11 1/2" deep

Shipping Weight
35 lbs. (15.9 kgs.)



BLENDING HIGH FIDELITY AND ARCHITECTURE®

Niles Audio Corporation
12331 S.W. 130 Street Miami, Florida 33186
305-238-4373

1-800-BUY-HIFI www.nileaudio.com

©2007 Niles Audio Corporation. All rights reserved. Niles, the Niles logos and Blending High Fidelity and Architecture are registered trademarks of Niles Audio Corporation. All other trademarks are the property of their respective owners. DS00628A

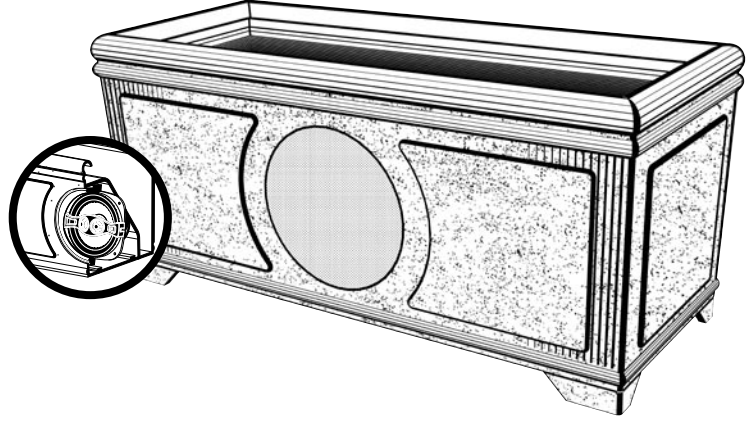
INSTALLATION GUIDE

FOR USE IN INDOOR OR OUTDOOR MUSIC SYSTEMS
STEREO INPUT PLANTER BOX SPEAKER

PB6Si

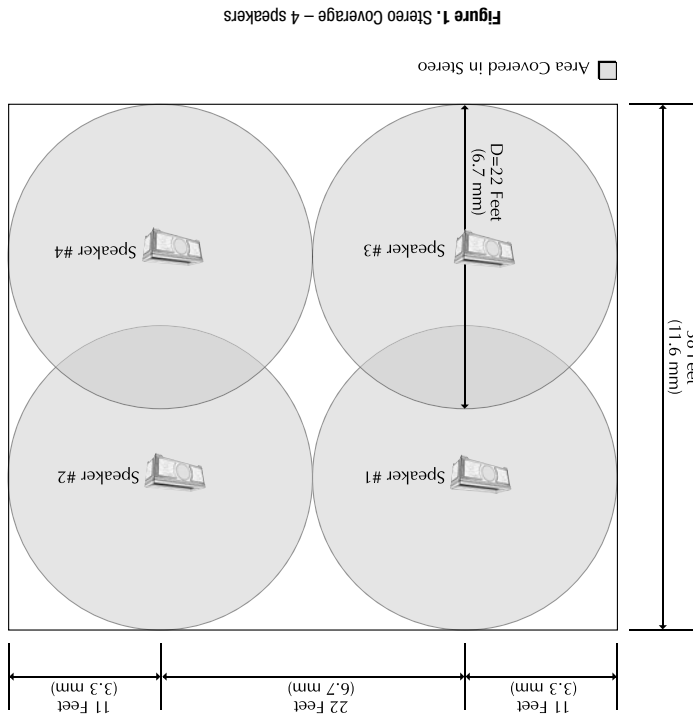

Figure 1. Stereo Coverage - 4 speakers

Figure 1 shows how this would work for a square area of 44 feet by 38 feet and using the PB6Si's in the one-speaker stereo mode. The loudspeaker coverage pattern is shown in the diagram. With the loudspeakers wired in the one-speaker stereo mode you can cover large areas with the highest quality stereo imaging available.

In one-speaker stereo mode, each connection cable of the PB6Si loudspeaker is connected to a separate amplifier channel and each loudspeaker cabinet plays in stereo. This configuration gives you the benefit of covering a larger area than the two-speaker stereo mode. The loudspeakers can be spaced 11 feet from the sides of the listening area and 22 feet from each other. The row spacing between speakers should be less than 38 feet. These loudspeaker spacing rules are the recommended maximums; placing speakers at a greater distance apart will negatively affect sound coverage and produce spots within the listening area where the sound quality will be poor.

SINGLE SPEAKER STEREO MODE

The PB6Si loudspeaker can be installed on a wood deck or on a concrete/stone patio. There are three considerations for placing the loudspeaker: connecting each cabinet in one-speaker stereo mode or two-speaker stereo mode, ease of running the cable to the loudspeaker and aimed on or near the loudspeaker. While the loudspeaker is weatherproof, continuous streaming water will shorten the product's life. The PB6Si loudspeaker will cover an area of a circle with a 22-foot diameter, in front of the speaker.

SELECTING THE NUMBER AND LOCATION FOR YOUR SPEAKERS

- Cable (length and type determined by installation site)
- A wire stripper

Tools and Materials Required:

INSTALLATION CONSIDERATIONS

Thank you for choosing the **PB6Si Planter Speaker** from Niles. With proper installation and operation, you'll enjoy years of trouble free use. Niles manufactures the industry's most complete line of custom installation components and accessories for audio/video systems. To see the complete assortment, visit our website at www.nileaudio.com.

CONGRATULATIONS!

ONE-SPEAKER STEREO MODE VS TWO-SPEAKER STEREO MODE

One-speaker stereo mode has the advantage of covering a larger area than the two-speaker stereo mode. The trade off between the two configurations is volume. The two-speaker stereo configurations will be able to play louder in its area than the one-speaker stereo configuration.

INCORPORATING A VOLUME CONTROL

It is possible to control the volume of the sound at the speaker location. Volume controls are connected in line with the speaker. An example of wiring an area with 2 speakers and a master volume control is shown in **Figure 2** for one-speaker stereo mode, and **Figure 3** for two-speaker stereo mode. It is usually desirable to control the volume of the speakers in different areas or zones of the outdoor system. A suggested way to accomplish this is shown in **Figure 4** for one-speaker stereo mode, and **Figure 5** for two-speaker stereo mode.

Niles recommends our standard weatherproof volume control, WVC100 series or our weatherproof muting volume control, WMVC series. In addition to controlling the volume of the loudspeakers, these controls allow the addition of added speakers without adding more amplifier channels.

INSTALLATION

CONNECTING THE LOUDSPEAKER IN ONE-SPEAKER STEREO MODE

- Strip two to three inches of each speaker cable's outer jacket away from the insulated conductors. Ensure that at least two inches of the separate conductors are free.
- Strip one half inch of insulation from the end of each conductor for both connection cables.
- Observe proper phasing when performing the following: Choose the speaker cable that is labeled for the "Right" amplifier channel. Using a wire nut, connect one stripped end of the "Right" speaker cable to the PB6Si connection cable's red wire. The wire nut will protect the stripped ends of the wire. If added protection is desired, place a large amount of silicon sealant so the bottom of the wire nut is encased and sealed. Repeat with the PB6Si connection cable's black wire and the other stripped amplifier "Right" speaker cable's conductor.
- Repeat steps 3 and 4 for the "Left" speaker cable and the PB6Si's connection cable with the "yellow/black" pair of conductors.
- Connect the opposite end of the speaker cables to the amplifier or receiver. Start by performing step 1 and 2 on the speaker cable near the amplifier. Use the cable labeled "Right" and attach the same conductor you attached to the red loudspeaker wire to the positive (red) or (+) "Right" amplifier output terminal. Attach the other conductor in that cable to the amplifier's "Right" negative (black) or (-) amplifier output terminal.
- Using the cable labeled "Left" attach the same conductor you attached to the yellow loudspeaker wire to the positive (red) or (+) "Left" amplifier output terminal. Attach the other conductor in that cable to the amplifier's "Left" negative (black) or (-) amplifier output terminal.

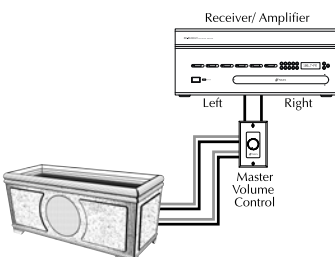

Figure 2. One-speaker stereo, one zone volume control wiring

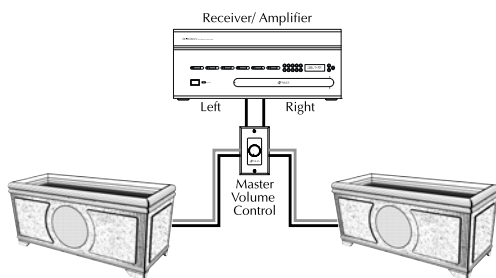

Figure 3. Two-speaker stereo, one zone volume control wiring

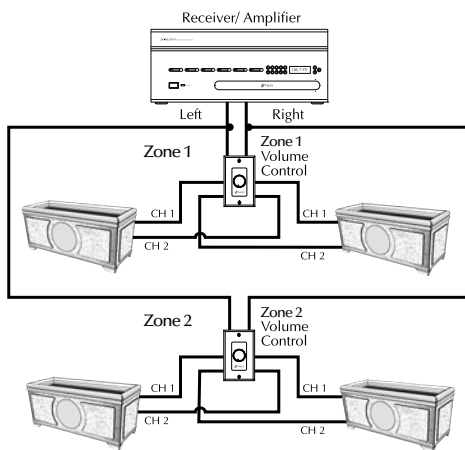

Figure 4. One-speaker stereo, two zone volume control wiring

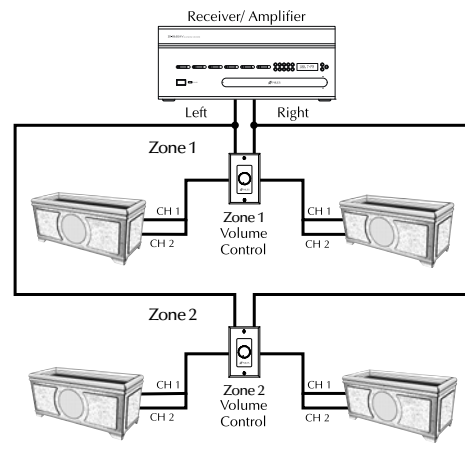

Figure 5. Two-speaker stereo, two zone volume control wiring

CONNECTING THE LOUDSPEAKER IN TWO-SPEAKER STEREO MODE

- Strip two to three inches of each speaker cable's outer jacket away from the insulated conductors. Ensure that at least two inches of the separate conductors are free.
- Strip one half inch of insulation from the end of each conductor for both connection cables.
- Connect one stripped end of the speaker cable coming from the amplifier to the PB6Si connection cable's red wire of one cable and the PB6Si connection cable's yellow wire. To connect the three wires, twist the stripped ends of the wire together and screw down the wire nut on the twisted wires. The material inside the wire nut will protect the stripped ends of the wire. However, if added protection is desired, place a large amount of silicon sealant so the bottom of the wire nut is encased and sealed. Pay attention to the markings on the speaker cable. Each loudspeaker you connect must be connected to the amplifier's speaker wire in the same way.
- Repeat step 3 with the PB6Si connection cable's black wires and the other stripped amplifier speaker cable's conductor.
- Connect the opposite end of the speaker cable to the amplifier or receiver. Start by performing step 1 and 2 on the speaker cable near the amplifier. Paying attention to the markings on the speaker cable conductor, attach the same conductor you attached to the red loudspeaker wire to the positive (red) or (+) amplifier output terminal. Attach the other conductor to the amplifier's negative (black) or (-) amplifier output terminal.

TROUBLESHOOTING

VERIFY SYSTEM OPERATION AND LOUDSPEAKER COVERAGE

- Turn the system "On" and play music to the speakers. Set the Volume controls to a level that allows the speakers to be easily heard over the "noise" in the area.
- Verify that music is playing through each speaker. If not, troubleshoot the wiring and make sure each speaker is electrically connected to the amplifier.
- Verify that each speaker is connected to the proper channel of the amplifier. To do this, change the balance of your speakers on your amplifier or receiver so that one channel is playing loudly and the other is not. Verify that each speaker or each side of the speaker is attached to the proper channel of the amplifier. If they are not, correct the wiring on the loudspeaker that is not connected properly. Reset the balance on the amplifier or receiver so both channels have a similar volume level.
- If you used a volume control between the amplifier and the speakers, verify that it is controlling the volume of the loudspeakers in its zone. Repeat this for every volume control in the system. If it is not, correct the wiring.
- Position the loudspeakers per the layout and verify that the sound is even and consistent throughout the area.

LIMITED WARRANTY

Niles Audio Corporation (“NILES”) warrants to the original retail purchaser only that this product will be free of manufacturing defects in material and workmanship for the following periods and subject to the limitations and exclusions set forth below:

Lifetime Warranty

All Passive Loudspeaker Products (those not requiring AC or battery power).

Ten years from the date of purchase

All Other Passive Products (those not requiring AC or battery power).

Two years from the date of purchase

All Active Products (those requiring AC or battery power).

This warranty is not transferable to subsequent purchasers of the product. To obtain warranty service, contact the authorized dealer where you purchased your product or take the unit to the nearest authorized NILES dealer (with proof of purchase – claims made without proof of purchase will be denied) who will test the product and if necessary, forward it to NILES for service. If there are no authorized NILES dealers in your area, you must contact NILES to receive a factory Return Authorization Number. **DO NOT RETURN ANY UNIT WITHOUT FIRST RECEIVING WRITTEN AUTHORIZATION AND SHIPPING INSTRUCTIONS FROM NILES.**

Upon examination, NILES will, at its sole option and expense, repair or replace any product found to be defective. NILES will return the repaired or replaced unit to you via its usual shipping method from the factory to your address in the United States of America or Canada only. Any shipping costs for addresses outside of the United States or Canada shall be the responsibility of the purchaser. In the event that this model is no longer available and cannot be repaired effectively, NILES, at its sole option, may replace it with a different model of equal or greater value, or refund the original purchase price paid. **THE FOREGOING ARE YOUR EXCLUSIVE REMEDIES FOR BREACH OF WARRANTY.**

This Warranty does not include service or parts to repair damage caused by improper use or handling, including but not limited to damage caused by accident, mishandling, improper installation, commercial use, abuse, negligence, or normal wear and tear, or any defect caused by repair to the product by anyone other than NILES.

This warranty does not cover reimbursement for your costs of removing and transporting the product for warranty service evaluation, or installation of any replacement product provided under this warranty.

This Warranty will be void if:

- the Serial Number on the product has been removed, tampered with or defaced.
- the product was not purchased from an authorized dealer or reseller.

THE FOREGOING WARRANTIES ARE EXCLUSIVE AND IN LIEU OF ALL OTHER EXPRESSED AND IMPLIED WARRANTIES. NILES EXPRESSLY DISCLAIMS ALL SUCH OTHER WARRANTIES, INCLUDING BUT NOT LIMITED TO IMPLIED WARRANTIES OF MERCHANTABILITY, FITNESS FOR A PARTICULAR PURPOSE AND NON-INFRINGEMENT, WITH RESPECT TO THE PRODUCT. TO THE MAXIMUM EXTENT PERMITTED BY LAW, NILES SHALL NOT BE RESPONSIBLE FOR ANY INCIDENTAL OR CONSEQUENTIAL DAMAGES EXCEPT TO THE EXTENT PROVIDED (OR PROHIBITED) BY APPLICABLE LAW, EVEN IF NILES HAS BEEN ADVISED OF THE POSSIBILITY OF SUCH DAMAGES.

Notwithstanding the above, if you qualify as a “consumer” under the Magnuson-Moss Warranty Act, or applicable state laws, then you may be entitled to any implied warranties allowed by law for the Warranty Period. Further, some states do not allow limitations on how long an implied warranty lasts or allow the exclusion or limitation of consequential damages, so such limitations may not apply to you. This warranty gives you specific legal rights, and you may also have other rights which vary from state to state.

For the name of your nearest authorized NILES dealer, contact: NILES AUDIO CORPORATION, P.O. BOX 160818, Miami, Florida 33116-0818, or call 1-800-289-4434. Please be advised that NILES only sells its products via the Internet through a select group of authorized Internet dealers. These are listed on our website at www.nilesaudio.com. Products offered on the Internet through unauthorized Internet dealers are not covered by the NILES warranty and may be either:

- 1) goods acquired on a secondary or grey market
- 2) counterfeit or stolen goods
- 3) damaged, or defective goods

Please fill in your product information and retain for your records.

Model_____	Serial No._____	Purchase Date_____
------------	-----------------	--------------------

ATTENTION: TO OUR VALUED CONSUMERS:

To insure that consumers obtain quality pre-sale and after-sale support and service, NILES products are sold exclusively through authorized dealers. This warranty is VOID if the products have been purchased from an unauthorized dealer.