

AX1



BX1



CX2



DX4



①

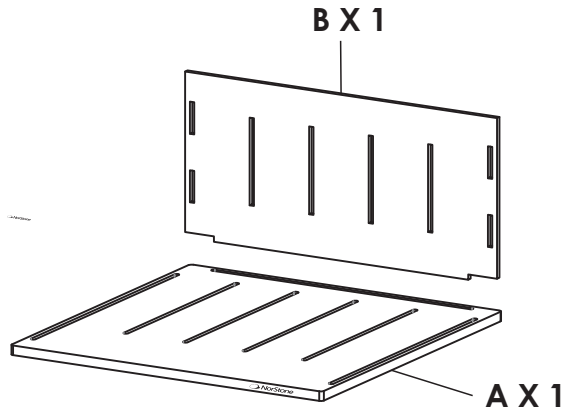

②

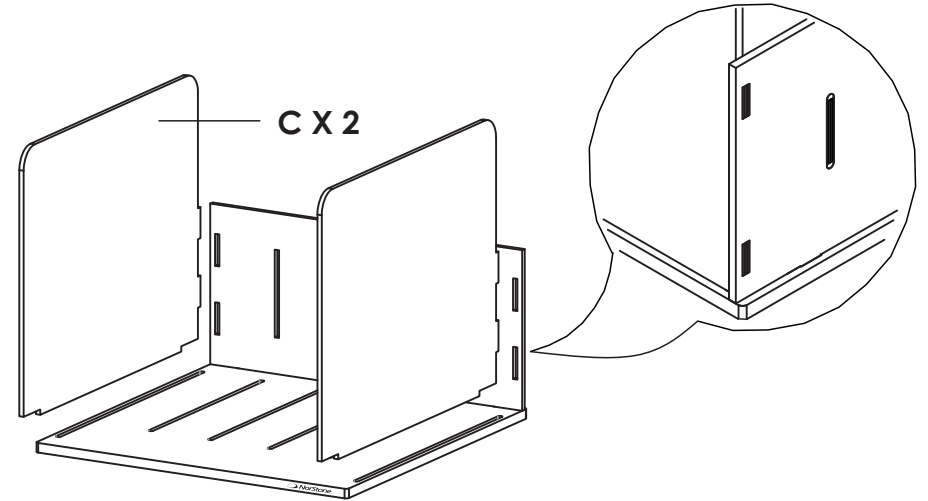

③

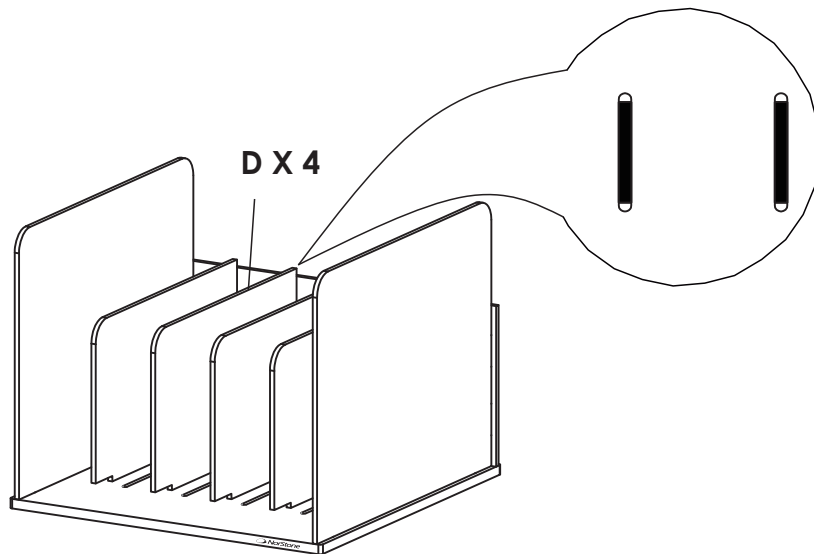

④

